

Identification of the product

HPM Anchor Bolts are available in standard models (16, 20, 24, 30, and 39) analogous to the M-thread diameter of the bolt. The model of anchor bolt can be identified by the name in the label on the product and the color of the product.

Forming a bolt group

Bolts are collected into bolt groups using the PPL Installation Template. The installation template enables bolt groups to be centralized on the horizontal plane in exactly the right place and easily adjusted to the correct casting level.

HPM Anchor Bolt color identification.

Anchor Bolt	Thread diameter [mm]	Color code	Installation Template
HPM 16	16	Yellow	PPL 16
HPM 20	20	Blue	PPL 20
HPM 24	24	Gray	PPL 24
HPM 30	30	Green	PPL 30
HPM 39	39	Orange	PPL 39

The PPL Installation Template is a steel plate. Anchor Bolts are fixed through the holes on the template with nuts and washers. The PPL installation plate has alignment marks for accurate positioning of the anchor bolt group. Anchor bolts also have center marks on the top of each bolt for alternative positioning methods. To prevent displacement during the concreting process, the template should be fixed securely to the supporting base by its fixing recesses at the sides. Concrete can be poured easily through the hole in the middle of the template. After casting, the installation template is detached and can be reused.



Ordering PPL Installation Templates

When PPL Installation Templates are ordered the thread diameter of bolts, the number of bolts and the center-to-center dimensions must be specified.

Examples of installation plates:

1. **PPL39-4** 360x360: 4 pieces M39 bolts in square form.
2. **PPL39-4** 500x400: 4 pieces M39 bolts in rectangular form.
3. **PPL30-6** 280x(190+190): 6 pieces M30 bolts rectangular form.
4. **PPL30-8** (190+190)x(190+190): 8 pieces M30 bolts in the form of a square.
5. **PPL30-3** 300x300: 3 pieces M30 bolts in the form of rectangular triangles.
6. **PPL24-8** D400: 8 pieces M24 bolts in the form of circles with diameter of 400 mm.

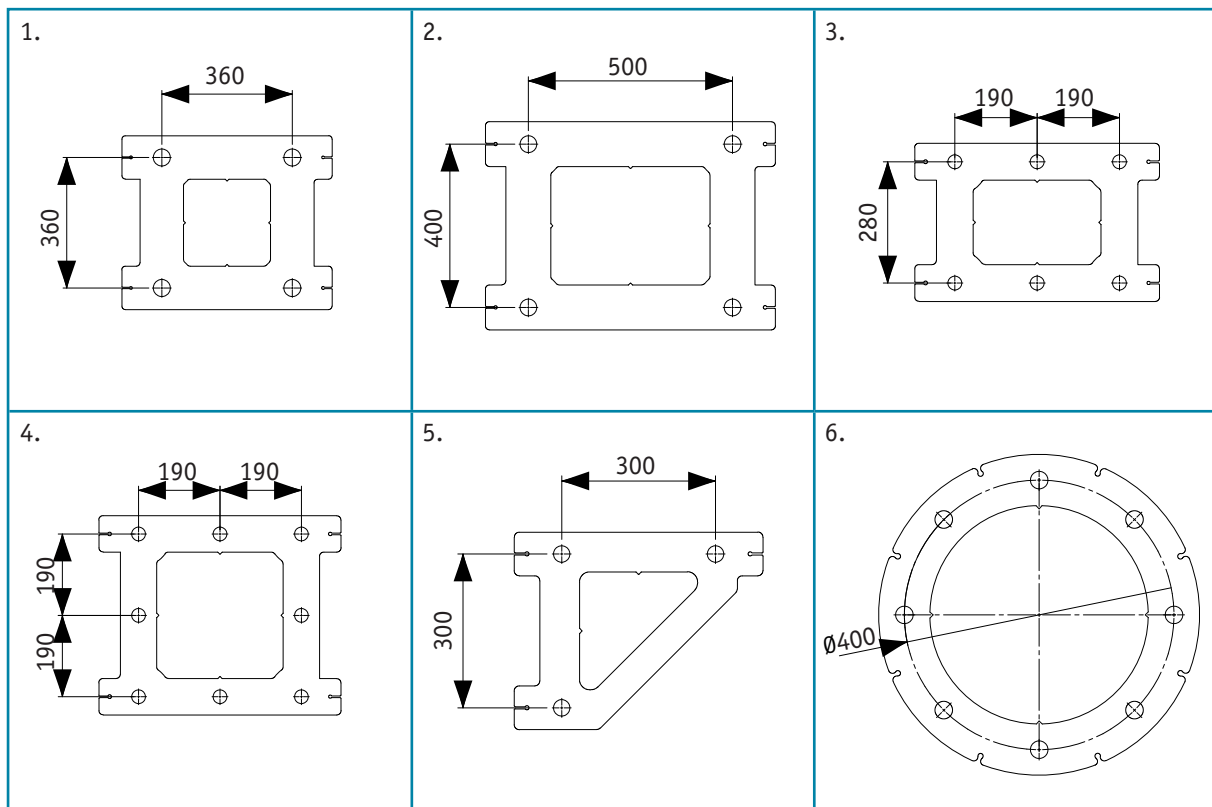

PPL Installation Templates can also be manufactured according to drawings that present the location of the bolts and thread diameters.

Bolt installation and installation tolerances

The bolts are installed to the height level according to dimension h_b given in table below. The height level is measured from the surface of concrete, and the level tolerance is ± 20 mm. Each anchor bolt includes a marking of the anchorage depth.

Installation tolerances and the anchor bolt's protrusion from the concrete.

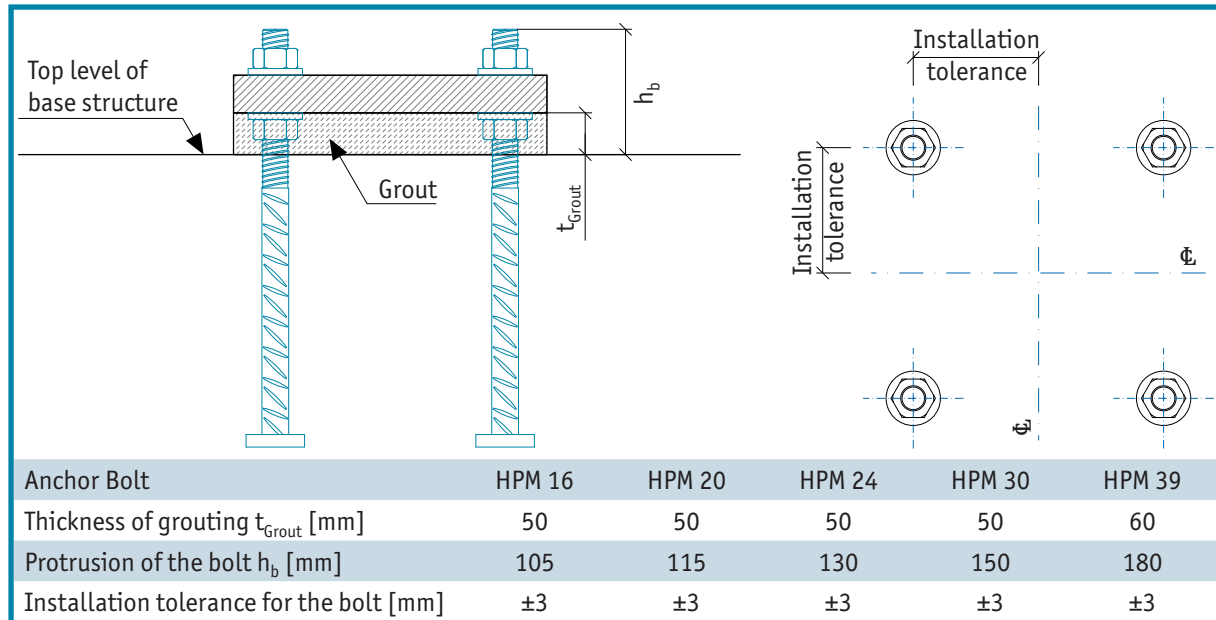

Bending the bolts

HPM Anchor Bolts are made of B500B ribbed reinforcement steel. Bending must be done in accordance with EN 1992-1-1. See Annex E of this manual with application examples.

Welding the bolts

Welding of the bolts should be avoided, although all materials used in HPM Anchor Bolts are weldable (except the nuts). Requirements and instructions of standard EN 17660-1: Welding of reinforcing steel, Part 1: load bearing welding joints shall be taken into account when welding rebars.

Existing buildings

When placing anchor bolts adjacent to walls or other obstructions, construction sequences should be considered. It is necessary to check that the erector will have enough access to tighten the nuts. If special setting is required, please contact Peikko Technical Support.

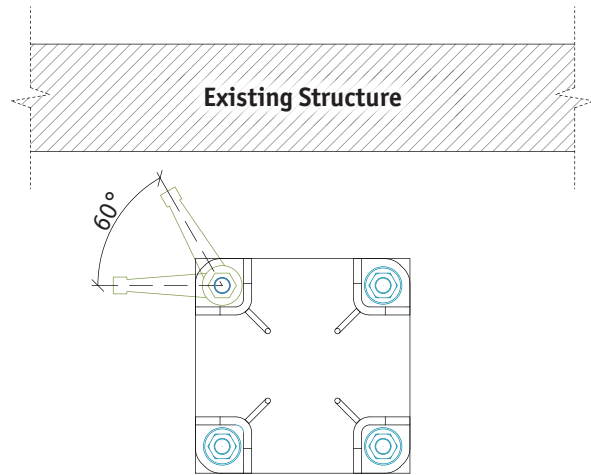

Erection of the attachment

Before erecting the attachment, the upper nuts and washers are removed from the anchor bolts. The lower leveling nuts and washers are adjusted to the correct level. The attachment is erected directly on the pre-leveled washers and nuts. An alternative method is to place shims between anchor bolts and adjust them to the proper level. The lower leveling nuts must be leveled at least 5 mm under the top level of shims to ensure that the attachment will rest first on the shims.

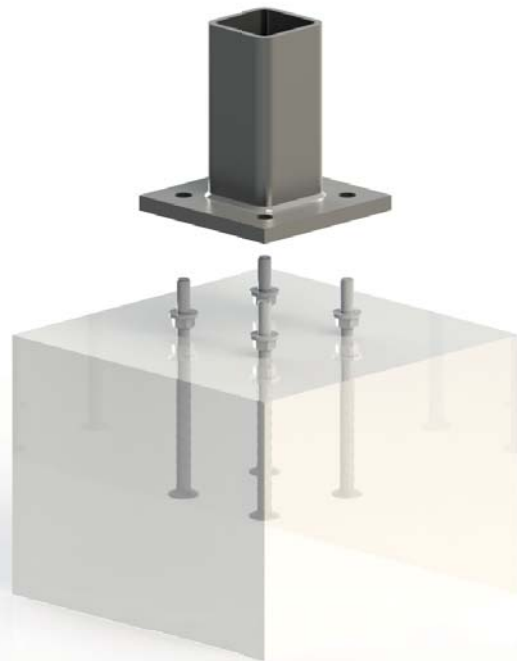

Securing the connection

The upper nuts and washers are screwed onto the bolts and the attachment is aligned in the vertical position using leveling nuts. It is practical to use two theodolites from different directions to ensure verticality. The nuts are tightened at least to the minimum torque given in the table below. Adequate torque can be achieved typically by 10–15 impacts of a slogging ring wrench (DIN 7444) or open-ended slogging wrench (DIN 133) and a 1,5 kg sledgehammer.

Recommended minimum T_{min} and maximum T_{max} torque values of nuts.

Anchor Bolt	T_{min} [Nm]	T_{max} [Nm]	Size of the slogging wrench
HPM 16	120	170	24 mm
HPM 20	150	330	30 mm
HPM 24	200	570	36 mm
HPM 30	250	1150	46 mm
HPM 39	350	2640	60 mm



Grouting the joint

Before loading the attachment with any other structures the joint must be grouted following the grout supplier's instructions. The grouting must be non-shrinking and have a strength according to the plans. To avoid air being trapped in the joint, it is recommended that grout be poured from one side only. Grouting formwork is made so that adequate concrete cover for anchor bolts is achieved.



Instructions for controlling bolt installation

Before casting:

- Ensure that the right PPL Installation Template is being used (axial distances, thread size)
- Verify the location of the bolt group
- Ensure that the reinforcement required by the bolts has been installed
- Ensure that the bolts are at the correct level
- Ensure that the installation plate and bolt group are not rotated
- Ensure that the bolt group is fixed in such a way that no movement can occur during casting

After casting:

- Ensure that the location of the bolt group is within the allowance for tolerance. Greater variations must be reported to the structural designer
- Protect the thread until the erection of the attachment (tape, plastic tube, etc.)

Instructions for controlling attachment installation

The joints must be made according to the installation plan drafted by the structural designer. If needed, Peikko's technical support can provide advice.

Check the following:

- The installation order
- Supports and bracing during installation
- Instructions for tightening the nuts
- Instructions for joint casting